

PLEASE NOTE!

The photos in this manual are for general instruction only. Your specific model may not be shown. Always refer to the parts list and exploded view drawing for your specific model when installing, disassembling or servicing your pump.

PRINCIPLE OF OPERATION

This ball valve pump is powered by compressed air and is a 1:1 pressure ratio design. It alternately pressurizes the inner side of one diaphragm chamber, while simultaneously exhausting the other inner chamber. This causes the diaphragms, which are connected by a common rod, to move endwise. Air pressure is applied over the entire surface of the diaphragm, while liquid is discharged from the opposite side. The diaphragm operates under a balanced condition during the discharge stroke, which allows the unit to be operated at discharge heads over 200 feet (61 meters) of water head.

Since the diaphragms are connected by a common rod, secured by plates to the center of the diaphragms, one diaphragm performs the discharge stroke, while the other is pulled to perform the suction stroke in the opposite chamber.

For maximum diaphragm life, keep the pump as close to the liquid being pumped as possible. Positive suction head in excess of 10 feet of liquid (3.048 meters) may require a back pressure regulating device. This will maximize diaphragm life.

Alternate pressuring and exhausting of the diaphragm chamber is performed by means of an externally mounted, pilot operated, four-way spool type air distribution valve. When the spool shifts to one end of the valve body, inlet air pressure is applied to one diaphragm chamber and the other diaphragm chamber exhausts. When the spool shifts to the opposite end of the valve body, the porting of chambers is reversed. The air distribution valve spool is moved by an internal pilot valve which alternately pressurizes one side of the air distribution valve spool, while exhausting the other side. The pilot valve is shifted at each end of the diaphragm stroke by the diaphragm plate coming in contact with the end of the pilot valve spool. This pushes it into position for shifting of the air distribution valve.

The chambers are manifolded together with a suction and discharge check valve for each chamber, maintaining flow in one direction through the pump.

INSTALLATION & START-UP

Locate the pump as close to the product being pumped as possible, keeping suction line length and number of fittings to a minimum. Do not reduce line size.

For installations of rigid piping, short flexible sections of hose should be installed between pump and piping. This reduces vibration and strain to the piping system. A Warren Rupp Tranquilizer® surge suppressor is recommended to further reduce pulsation in flow.

This pump was tested at the factory prior to shipment and is ready for operation. It is completely self-priming from a dry start for suction lifts of 10 feet (3.05 meters) or less. For suction lifts exceeding 10 feet of liquid, fill the chambers with liquid prior to priming.

AIR SUPPLY

Air supply pressures cannot exceed 100 psi (6.89 bar). Connect the pump air inlet to an air supply of sufficient capacity and pressure required for desired performance. When the air line is solid piping, use a short length of flexible hose (not less than ¾" (19mm) in diameter) between pump and piping to eliminate strain to pipes.

AIR INLET & PRIMING

For start-up, open an air valve approximately ½ to ¾ turn. After the unit primes, an air valve can be opened to increase flow as desired. If opening the valve increases cycling rate, but does not increase flow rate, cavitation has occurred, and the valve should be closed slightly.

⚠ IMPORTANT ⚠

Read these instructions completely, before installation and start-up. It is the responsibility of the purchaser to retain this manual for reference. Failure to comply with the recommendations stated in this manual will damage the pump, and void factory warranty.

⚠ WARNING ⚠

Take action to prevent static sparking. Fire or explosion can result, especially when handling flammable liquids. The pump, piping, valves, containers or other miscellaneous equipment must be grounded.

⚠ BEFORE OPERATION ⚠

Before pump operation, inspect all gasketed fasteners for looseness caused by gasket creep. Retorque loose fasteners to prevent leakage. Follow recommended torques stated in this manual

⚠ DANGER ⚠

Before doing any maintenance on the pump, be certain all pressure is completely vented from the pump, suction, discharge, piping, and all other openings and connections. Be certain the air supply is locked out or made non-operational, so that it cannot be started while work is being done on the pump. Be certain that approved eye protection and protective clothing are worn all times in the vicinity of the pump. Failure to follow these recommendations may result in serious injury or death.

⚠ HAZARD WARNING ⚠

POSSIBLE EXPLOSION HAZARD can result if 1, 1, 1-Trichloroethane, Methylene Chloride or other Halogenated Hydrocarbon solvents are used in pressurized fluid systems having Aluminum or Galvanized wetted parts. Death, serious bodily injury and/or property damage could result. Consult with the factory if you have questions concerning Halogenated Hydrocarbon solvents.

For the most efficient use of compressed air and the longest diaphragm life, throttle the air inlet to the lowest cycling rate that does not reduce flow.

AIR EXHAUST

If a diaphragm fails, the pumped liquid or fumes can enter the air end of the pump, and be exhausted into the atmosphere. When pumping hazardous or toxic materials, pipe the exhaust to an appropriate area for safe disposition.

This pump can be submerged if materials of construction are compatible with the liquid. The air exhaust must be piped above the liquid level. Piping used for the air exhaust must not be smaller than 1" (2.54 cm). Reducing the pipe size will restrict air flow and reduce pump performance. When the product source is at a higher level than the pump (flooded suction), pipe the exhaust higher than the product source to prevent siphoning spills.

Freezing or icing of the air exhaust can occur under certain temperature and humidity conditions. Use of an inline air dryer should eliminate most icing problems.

BETWEEN USES

When used for materials that tend to settle out or transform to solid form, the pump should be completely flushed after each use, to prevent damage. Product remaining in the pump between uses could dry out or settle out. This could cause problems with valves and diaphragms at re-start. In freezing temperatures, the pump must be drained between uses in all cases.

CHECK VALVE SERVICING

Need for inspection or service is usually indicated by poor priming, unstable cycling, reduced performance or the pump's cycling, but not pumping.

Inspect the surfaces of both check valves and seats for wear or damage that could prevent proper sealing. If pump is to prime properly, valves must seat air tight.

DIAPHRAGM SERVICING

Remove the eight bolts (four each side) securing the manifold assemblies to the outer chambers. Remove the eight bolts securing the outer chamber to the inner chamber. Remove the diaphragm assembly (outer plate, diaphragm, inner plate) by turning the assembly counterclockwise using a $1\frac{5}{16}$ " (2.38 cm) wrench on the outer plate lugs. To disassemble the diaphragm assemblies, secure in a vise and turn the outer plate counterclockwise using the $1\frac{5}{16}$ " wrench.

Procedures for reassembling the diaphragms are the reverse of the above. The diaphragms must be installed with their natural bulge to the outside, toward the outer diaphragm plate. Install the inner plate with the flat face against the diaphragm.

After all components are in position in a vise and hand tight, tighten with a wrench to approximately 40 ft. lbs. (54.23 Newton meters) torque. After both diaphragm assemblies have been assembled, thread one assembly into the shaft (hold the shaft near the middle in a vise with soft jaws, to protect the finish). Install this sub assembly into the pump and secure by placing the outer chamber on the end with the diaphragm. This holds the assembly in place while the opposite side is installed. Torque the last diaphragm assembly to 30 ft. lbs. (40.67 Newton meters). This final torquing will lock the diaphragm assemblies together. Place the remaining outer chamber on the open end and loosely tighten the bolts. Replace the manifold assemblies to square the flanges before final tightening of the remaining bolts.

A NOTE ABOUT AIR VALVE LUBRICATION

The SandPiper pump's pilot valve and main air valve assemblies are designed to operate WITHOUT lubrication. This is the preferred mode of operation. There may be instances of personal preference, or poor quality air supplies when lubrication of the compressed air supply is required. The pump air system will operate with properly lubricated compressed air supplies. Proper lubrication of the compressed air supply would entail the use of an air line lubricator (available from Warren Rupp) set to deliver one drop of 10 wt., non-detergent oil for every 20 SCFM of air the pump consumed at its point of operation. Consult the pump's published Performance Curve to determine this.

It is important to remember to inspect the sleeve and spool set routinely. It should move back and forth freely. This is most important when the air supply is lubricated. If a lubricator is used, oil accumulation will, over time, collect any debris from the compressed air. This can prevent the pump from operating properly.

CAUTION

If a diaphragm fails the pumped product or fumes can enter the air side of the pump. This side is exhausted through the exhaust port (muffler).

When the product is a hazardous or toxic material, the exhaust should be piped to an appropriate area for safe disposition.

When the product source is at a higher level than the pump (flooded suction), the exhaust should be piped to a higher level than the product to prevent spills caused by siphoning.

CAUTION

CAUTION: When removing capscrews on suction or discharge valve retainer/cap, make sure all pressure on suction and discharge side of pump has been relieved. Re-lock safety wire on the capscrews before continuing use.

CAUTION

In the event of diaphragm rupture, pumped material may enter the air end of the pump, and be discharged into the atmosphere. If pumping a product which is hazardous or toxic, the air exhaust must be piped to an appropriate area for safe disposition.

CAUTION

Before maintenance or repair, shut off the compressed air line, bleed the pressure, and disconnect the air line from the pump. The discharge line may be pressurized and must be bled of its pressure. When used for toxic or aggressive fluids, the pump should always be flushed clean prior to disassembly.

IMPORTANT

This pump is pressurized internally with air pressure during operation. Always make certain that all bolting is in good condition and that all of the correct bolting is reinstalled during assembly.

Water in the compressed air supply can create problems such as icing or freezing of the exhaust air causing the pump to cycle erratically, or stop operating. This can be addressed by using a point of use air dryer to supplement a plant's air drying equipment. This device will remove excess water from the compressed air supply and alleviate the icing or freezing problem.

ESADS: EXTERNALLY SERVICEABLE AIR DISTRIBUTION SYSTEM

Please refer to the exploded view drawing and parts list in the Service Manual supplied with your pump. If you need replacement or additional copies, contact your local Warren Rupp Distributor, or the Warren Rupp factory Literature Department at the number shown below. To receive the correct manual, you must specify the MODEL and TYPE information found on the name plate of the pump.

The main air valve sleeve and Spool set list located in the valve body mounted on the pump with four hex head capscrews. The valve body assembly is removed from the pump by removing these four hex head capscrews.

With the valve body assembly off the pump, access to the sleeve and spool set is made by removing four hex head capscrews (each end) on the end caps of the valve body assembly. With the end caps removed, slide the spool back and forth in the sleeve. The spool is closely sized to the sleeve and must move freely to allow for proper pump operation. An accumulation of oil, dirt or other contaminants from the pump's air supply, or from a failed diaphragm, may prevent the spool from moving freely. This can cause the spool to stick in a position that prevents the pump from operating. If this is the case, the sleeve and spool set should be removed from the valve body for cleaning and further inspection.

Remove the spool from the sleeve. Using an arbor press or bench vise (with an improvised mandrel), press the sleeve from the valve body. Take care not to damage the sleeve. At this point, inspect the o-rings on the sleeve for nicks, tears or abrasions. Damage of this sort could happen during assembly or servicing. A sheared or cut o-ring can allow the pump's compressed air supply to leak or bypass within the air valve assembly, causing the pump to leak compressed air from the pump air exhaust or not cycle properly. This is most noticeable at pump dead head or high discharge pressure conditions. Replace any of these o-rings as required or set up a routine, preventive maintenance schedule to do so on a regular basis. This practice should include cleaning the spool and sleeve components with a safety solvent or equivalent. Inspecting for signs of wear or damage, and replacing worn components.

To re-install the sleeve and spool set, lightly lubricate the o-rings on the sleeve with an o-ring assembly lubricant or lightweight oil (such as 10 wt. air line lubricant). Press the set into the valve body easily, without shearing the o-rings. Re-install one end cap, gasket and bumper on the valve body. Using the arbor press or bench vise that was used in disassembly, press the sleeve back into the valve body. You may have to clean the surfaces of the valve body where the end caps mount. Material may remain from the old gasket. Old material not cleaned from this area may cause air leakage after reassembly. Take care that the bumper stays in place allowing the sleeve to press in all the way. Reinstall the spool, the opposite end cap, gasket and bumper on the valve body. After inspecting and cleaning the gasket surfaces on the valve body and intermediate, reinstall the valve body on the pump using new gaskets. Tighten the four hex head capscrews evenly and in an alternating cross pattern.

PILOT VALVE

This assembly is reached by removing the air distribution valve body from the pump and lifting the pilot valve body out of the intermediate housing.

When reinserting an externally serviceable pilot valve, push both plungers out of the path of the pilot valve so that they and the pilot valve are not damaged.

Service Note: If a problem arises with the pilot valve, it is usually corrected by replacing only o-rings. Always grease the spool prior to inserting into the sleeve. If the sleeve is removed from the body, reinsertion must be from the same side it was removed from, the chamfered side. Again, grease the o-rings so that it slides into the body. Make sure the retaining ring has securely been inserted around the sleeve.

⚠ BEFORE OPERATION ⚠
Before pump operation, inspect all gasketed fasteners for looseness caused by gasket creep. Retorque loose fasteners to prevent leakage. Follow recommended torques stated in this manual

⚠ DANGER ⚠
Before doing any maintenance on the pump, be certain all pressure is completely vented from the pump, suction, discharge, piping, and all other openings and connections. Be certain the air supply is locked out or made non-operational, so that it cannot be started while work is being done on the pump. Be certain that approved eye protection and protective clothing are worn all times in the vicinity of the pump. Failure to follow these recommendations may result in serious injury or death.

PILOT VALVE ACTUATOR

The bushings for the pilot valve actuators are threaded into the intermediate bracket from the outside. The plunger may be removed for inspection or replacement from the inside by removing the air distribution valve body and the pilot valve body from the pump. The plungers should be visible as you look into the intermediate from the top. Depending on their position, you may find it necessary to use a fine piece of wire to pull them out.

Under rare circumstances, it may become necessary to replace the o-ring seal. The bushing can be turned out through the inner chamber by removing the outer chamber assembly to reach the bushing.

TROUBLE SHOOTING

1. Pump will not cycle

- A. Check to make sure the unit has enough pressure to operate and that the air inlet valve is open.
- B. Check the discharge line to insure that the discharge line is neither closed nor blocked.
- C. If the spool in the air distribution valve is not shifting, check the main spool. It must slide freely.
- D. Excessive air leakage in the pump can prevent cycling. This condition will be evident. Air leakage into the discharge line indicates a ruptured diaphragm. Air leakage from the exhaust port indicates leakage in the air distribution valve. See further service instructions.
- E. Blockage in the liquid chamber can impede movement of diaphragm.

2. Pump cycles but will not pump

- A. Suction side of pump pulling in air. Check the suction line for air leaks and be sure that the end of the suction line is submerged. Check flange bolting. Check valve flanges and manifold to chamber flange joints.
- B. Make certain the suction line or strainer is not plugged. Restriction at the suction is indicated by a high vacuum reading when a vacuum gauge is installed in the suction line.
- C. Check valves may not be seating properly. To check, remove the suction line and cover the suction port with your hand. If the unit does not pull a good suction (vacuum), the check valves should be inspected for proper seating.
- D. Static suction lift may be too high. Priming can be improved by elevating the suction and discharge lines higher than the check valves and pouring liquid into the unit through the suction inlet. When priming at high suction lifts or with long suction lines operate the pump at maximum cycle rate.

3. Low performance

- A. Capacity is reduced as the discharge pressure increases, as indicated on the performance curve. Performance capability varies with available inlet air supply. Check air pressure at the pump inlet when the pump is operating to make certain that adequate air supply is maintained.
- B. Check vacuum at the pump suction. Capacity is reduced as vacuum increases. Reduced flow rate due to starved suction will be evident when cycle rate can be varied without change in capacity. This condition will be more prevalent when pumping viscous liquids. When pumping thick, heavy materials the suction line must be kept as large in diameter and as short as possible, to keep suction loss minimal.
- C. Low flow rate and slow cycling rate indicate restricted flow through the discharge line. Low flow rate and fast cycling rate indicate restriction in the suction line or air leakage into suction.
- D. Unstable cycling indicates improper check valve seating on one chamber. This condition is confirmed when unstable cycling repeats consistently on alternate exhausts. Cycling that is not consistently unstable may indicate partial exhaust restriction due to freezing and thawing of exhaust air. Use of an anti-freeze lubricant in an air line lubricator should solve this problem.

For additional information, see the Warren Rupp Troubleshooting Guide.

WARRANTY

This pump is warranted for a period of five years against defective material and workmanship. Failure to comply with the recommendations stated in this manual voids all factory warranty.

⚠ BEFORE OPERATION ⚠

Before pump operation, inspect all gasketed fasteners for looseness caused by gasket creep. Retorque loose fasteners to prevent leakage. Follow recommended torques stated in this manual

⚠ DANGER ⚠

Before doing any maintenance on the pump, be certain all pressure is completely vented from the pump, suction, discharge, piping, and all other openings and connections. Be certain the air supply is locked out or made non-operational, so that it cannot be started while work is being done on the pump. Be certain that approved eye protection and protective clothing are worn all times in the vicinity of the pump. Failure to follow these recommendations may result in serious injury or death.

RECOMMENDED WARREN RUPP ACCESSORIES TO MAXIMIZE PUMP PERFORMANCE:

- Tranquilizer® Surge Suppressor. For nearly pulse-free flow.
- Warren Rupp programmable Batch Control or Pulse Output Interfaces for repeatable accuracy.
- Warren Rupp Speed Control. For manual or programmable process control. Manual adjustment or 4-20mA reception.

For more detailed information on these accessories, contact your local Warren Rupp Factory-Authorized Distributor, or Warren Rupp corporate headquarters.

© 2000 Warren Rupp, Inc. All rights reserved.

®Warren Rupp, SandPIPER, and Tranquilizer are registered tradenames of Warren Rupp, Inc.

®Neverseize is a registered tradename of Loctite

Printed in U.S.A.



REPAIR PARTS LIST and DRAWING

SandPIPER **EB2-M** **EB2-MB** **MEB2-M** **EB50M** Type 3

ITEM NO.	PART NUMBER	DESCRIPTION	TOTAL RQD.
1	070-006-170	Bearing, Sleeve	2
2	114-002-156	Bracket, Intermediate	1
	114-002-010	Bracket, Intermediate	1
3	720-004-360	Seal, U-Cup	2
4	135-008-000	Bushing, Threaded, with o-ring	2
	135-016-162	Bushing, Threaded, with o-ring (MEB2-M only)	2
5	620-004-114	Plunger, Actuator	2
	620-011-114	Plunger, Actuator (MEB2-M only)	2
6	095-073-000	Assembly, Pilot Valve*	1
6-A	095-070-551	Valve Body	1
6-B	755-025-000	Sleeve (with o-rings)	1
6-C	560-033-360	O-Ring (Sleeve)	4
6-D	775-026-000	Spool (with o-rings)	1
6-E	560-023-360	O-Ring (Spool)	2
6-F	675-037-080	Retaining Ring	1
7	360-041-425	Gasket, Valve Body	1
8	560-001-360	O-Ring	2
9	095-043-156	Body, Valve	1
	095-043-010	Body, Valve	1
10	132-014-358	Bumper, Valve Spool	2
11	165-011-157	Cap, End	2
	165-011-010	Cap, End	2
12	360-048-425	Gasket, Valve Body	1
13	360-010-425	Gasket, End Cap	2
14	560-020-360	O-Ring	6
15	031-012-000	Sleeve & Spool Set	1
16	170-032-330	Capscrew, Hex Head	8
	170-032-115	Capscrew, Hex Head	8
17	170-045-330	Capscrew, Hex Head	4
	170-045-115	Capscrew, Hex Head	4
18	132-002-360	Bumper, Diaphragm	2
19	196-001-157	Chamber, Inner	2
	196-001-010	Chamber, Inner	2
20	286-007-365	Diaphragm	2
	286-007-363	Diaphragm	2
	286-007-360	Diaphragm	2
	286-007-366	Diaphragm	2
	286-007-364	Diaphragm	2
	286-007-356	Diaphragm	2
21	560-022-360	O-Ring	2
22	685-007-120	Rod, Diaphragm	1
23	170-023-330	Capscrew, Hex Head	16
	170-023-115	Capscrew, Hex Head	16
24	170-024-330	Capscrew, Hex Head	8
	170-024-115	Capscrew, Hex Head	8
25	618-003-330	Plug, Pipe (SS & Alloy C Qty.2)	4
	618-003-110	Plug, Pipe (SS Only) (AX Qty. 4)	2
	618-003-112	Plug, Pipe (Alloy C Only)	2
26	900-006-330	Washer, Lock	8
	900-006-115	Washer, Lock	8
27	612-047-330	Plate, Diaphragm	2
28	612-039-157	Plate, Outer	2
	612-097-110	Plate, Outer	2
	612-039-010	Plate, Outer	2
29	807-026-330	Stud	2

Repair Parts shown in **bold face (darker)** type are more likely to need replacement after extended periods of normal use. They are readily available from most Warren Rupp distributors. The pump owner may prefer to maintain a limited inventory of these parts in his own stock to reduce repair downtime to a minimum.

IMPORTANT: When ordering repair parts always furnish pump model number, serial number and type number.

MATERIAL CODES The Last 3 Digits of Part Number

000...	Assembly, sub-assembly; and some purchased items
010...	Cast Iron
012...	Powered Metal
015...	Ductile Iron
020...	Ferritic Malleable Iron
025...	Music Wire
080...	CarbonSteel AISI B-1112
100...	Alloy 20
110...	Alloy Type 316 Stainless Steel
111...	Alloy Type 316 Stainless Steel (Electro Polished)
112...	Alloy "C"
113...	Alloy Type 316 Stainless Steel (Hand Polished)
114...	303 Stainless Steel
115...	302/304 Stainless Steel
117...	440-C Stainless Steel (Martensitic)
120...	416 Stainless Steel (Wrought Martensitic)
123...	410 Stainless Steel (Wrought Martensitic)
148...	Hardcoat Anodized Aluminum
149...	2024-T4 Aluminum
150...	6061-T6 Aluminum
151...	6063-T6 Aluminum
152...	2024-T4 Aluminum (2023-T351)
154...	Almag 35 Aluminum
155 or 156...	356-T6 Aluminum
157...	Die Cast Aluminum Alloy #380
158...	Aluminum Alloy SR-319
159...	Anodized Aluminum
162...	Brass, Yellow, Screw Machine Stock
165...	Cast Bronze, 85-5-5-5
166...	Bronze SAE 660
170...	Bronze, Bearing Type, Oil Impregnated
180...	Copper Alloy
310...	Kynar Coated
330...	Zinc Plated Steel
331...	Chrome Plated Steel
332...	Electroless Nickel Plated
335...	Galvanized Steel
336...	Zinc Plated Yellow Brass
337...	Silver Plated Steel
340...	Nickel Plated
342...	Filled Nylon
354...	Injection Molded #203-40 Santoprene - Duro 40D ± 5; Color: RED
355...	Thermoplastic Elastomer
356...	Hytre
357...	Rupplon (Urethane Rubber) Color coded: PURPLE
358...	Rupplon (Urethane Rubber) Color coded: PURPLE (Some Applications, Compression Mold)
359...	Urethane Rubber
360...	Buna-N Rubber Color coded: RED
361...	Buna-N
363...	Viton (Fluorel) Color coded: YELLOW
364...	E.P.D.M. Rubber Color coded: BLUE
365...	Neoprene Rubber Color coded: GREEN
370...	Butyl Rubber Color coded: BROWN
371...	Philtane (Tuftane)

List continued next page

*Available in Kit Form. Order P/N 031-055-000 which also includes items 5, 7, 12 & 47.

ITEM NO.	PART NUMBER	DESCRIPTION	TOTAL RQD.
31	545-007-330	Nut, Hex	16
	545-007-115	Nut, Hex	16
32	722-040-365	Seat, Valve	4
	722-069-360	Seat, Valve (Cast Iron Only)	4
	722-069-363	Seat, Valve (Cast Iron Only)	4
	722-069-364	Seat, Valve (Cast Iron Only)	4
	722-069-365	Seat, Valve (Cast Iron Only)	4
	722-069-600	Seat, Valve (Cast Iron Only)	4
	722-040-363	Seat, Valve	4
	722-040-360	Seat, Valve	4
	722-040-364	Seat, Valve	4
	722-040-600	Seat, Valve	4
	722-040-110	Seat, Valve (See NOTE Below)	2
33	050-017-365	Ball, Check Valve	4
	050-017-360	Ball, Check Valve	4
	050-017-364	Ball, Check Valve	4
	050-018-600	Ball, Check Valve	4
34	518-032-156	Manifold, Suction (NPT EB2-M Only)	1
	518-032-110	Manifold, Suction (NPT EB2-M Only)	1
	518-032-010	Manifold, Suction (NPT EB2-M Only)	1
	518-032-156E	Manifold, Suction (BSP EB50M)	1
	518-032-010E	Manifold, Suction (BSP EB50M) (3 Bolt)	1
	518-032-110E	Manifold, Suction (BSP EB50M)	1
35	518-033-156	Manifold, Discharge (NPT)	1
	518-033-110	Manifold, Discharge (NPT)	1
	518-033-010	Manifold, Discharge (NPT) (3 Bolt)	1
	518-033-156E	Manifold, Discharge (BSP EB50M)	1
	518-033-110E	Manifold, Discharge (BSP EB50M)	1
	518-033-010E	Manifold, Discharge (BSP EB50M)	1
36	902-003-000	Stat-O-Seal	2
37	170-066-330	Capscrew, Hex Head. (EB2-MB Qty. 4)(CI Qty.12)	8
	170-066-115	Capscrew, Hex Head. (EB2-MB Qty. 4)(CI Qty.12)	8
38	900-003-330	Washer, Lock (CI Qty.12)	8
	900-003-115	Washer, Lock (CI Qty.12)	8
	901-006-330	Washer, Flat (Used on CI Units)	12
39	545-008-330	Nut, Hex (Not Used on CI Units)	8
	545-008-110	Nut, Hex (Not Used on CI Units)	8
41	196-047-156	Chamber, Outer	2
	196-047-110	Chamber, Outer	2
	196-047-010	Chamber, Outer	2
42	530-008-000	Muffler, Exhaust	1
43	326-003-080	Mounting Feet (SS & Alloy C Only)	2
44	170-024-330	Capscrew, Hex Head (SS & Alloy C Only)	4
45	900-006-330	Washer, Flat (SS & Alloy C Only)	4
46	286-020-604	Overlay Diaphragm	2
47	132-022-360	Bumper	2
48	800-012-158	Base, Strainer (EB2-MB Only)	1
49	518-044-156	Manifold, Suction (EB2-MB Only)	1
50	170-055-330	Capscrew, Hex Head (EB2-MB Only)	4
51	258-016-158	Cover, Suction (EB2-MB Only)	1
52	170-035-330	Capscrew, Hex Head (EB2-MB Only)	1
53	900-006-330	Washer, Lock (EB2-MB Only)	1
54	031-019-156	Main Air Valve Assembly (Inc. Items 9,10,11,13, 14, 15, 16)	1
	031-019-010	Main Air Valve Assembly	1
	031-053-156	Main Air Valve Assembly (EB2M, TB3AX & TN3AX units)	1

Repair Parts shown in **bold face (darker)** type are more likely to need replacement after extended periods of normal use. They are readily available from most Warren Rupp distributors. The pump owner may prefer to maintain a limited inventory of these parts in his own stock to reduce repair downtime to a minimum.

IMPORTANT: When ordering repair parts always furnish pump model number, serial number and type number.

MATERIAL CODES
The Last 3 Digits of Part Number

Continued from previous page

375...	Fluorinated Nitrile
378...	High density Polypropylene
405...	Cellulose Fibre
408...	Cork and Neoprene
425...	Compressed Fibre
426...	Blue Gard
440...	Vegetable Fibre
465...	Fibre
500...	Delrin 500
501...	Delrin 570
505...	Acrylic Resin Plastic
520...	Injection Molded PVDF Natural Color
540...	Nylon
541...	Nylon
542...	Nylon
544...	Nylon Injection Molded
550...	Polyethylene
551...	Polypropylene
552...	Unfilled Polypropylene
553...	Unfilled Polypropylene
555...	Polyvinyl Chloride
570...	Rulon II
580...	Ryton
590...	Valox
591...	Nylatron G-S
592...	Nylatron NSB
600...	Teflon (virgin material) Tetrafluoroethylene (TFE)
601...	Teflon (Bronze and moly filled)
602...	Filled Teflon
603...	Blue Gylon
604...	Teflon
606...	Teflon
610...	Teflon Encapsulated Silicon
611...	Teflon Encapsulated Viton

Delrin, Teflon, Viton and Hytrel are registered tradenames of E.I. DuPont.

Gylon is a registered tradename of Garlock, Inc.

Nylatron is a registered tradename of Polymer Corp.

Rulon II is a registered tradename of Dixon Industries Corporation.

Hastelloy-C is a registered tradename of Cabot Corp.

Ryton is a registered tradename of Phillips Chemical Company.

Valox is a registered tradename of General Electric Company.

Warren Rupp, Rupplon, SandPIPER, PortaPump, Tranquilizer, and SludgeMaster are registered tradenames of Warren Rupp Inc.

NOTE: For special construction pumps equipped with stainless steel check valve seat 722-040-110 check the configuration of the seat o-ring groove.

a) If the groove is open-end on the outer diameter order the 560-085-611 o-ring.

b) If the groove is a smaller diameter with three sides order the 720-060-600 PTFE seal.

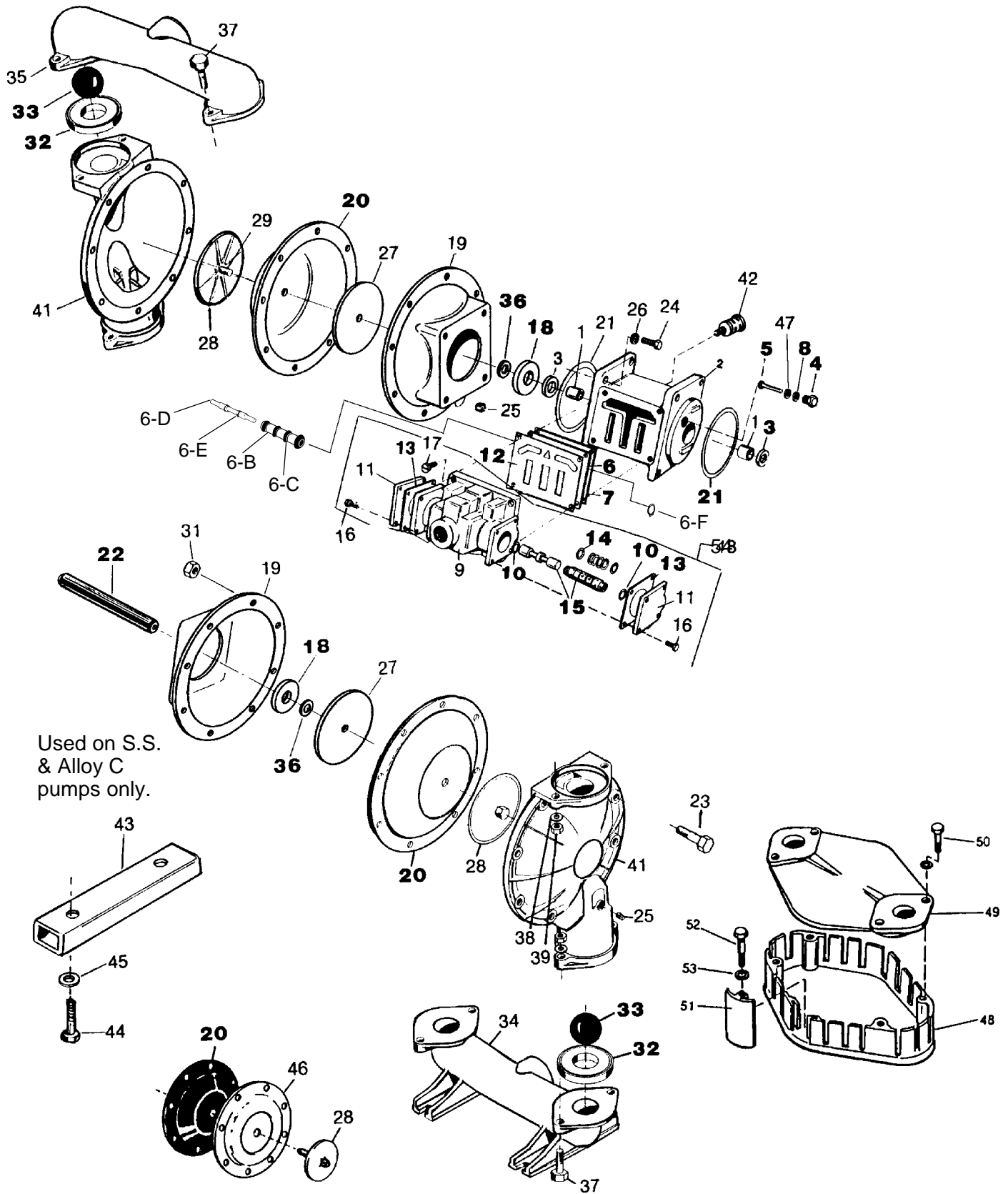

Used on S.S.
& Alloy C
pumps only.

Diaphragm when used with overlay.
Ribs are toward pumped material.

© 2002 Warren Rupp, Inc. All rights reserved.
©Warren Rupp and SandPIPER are registered tradenames of Warren Rupp, Inc.
Printed in U.S.A.