

Homogeneizador industrial

(5,5, 7,5 y 11 kW)

**DOSIER DE PLANOS DIMENSIONALES**

BRIDA EN1092-1-05 PN16 DN50

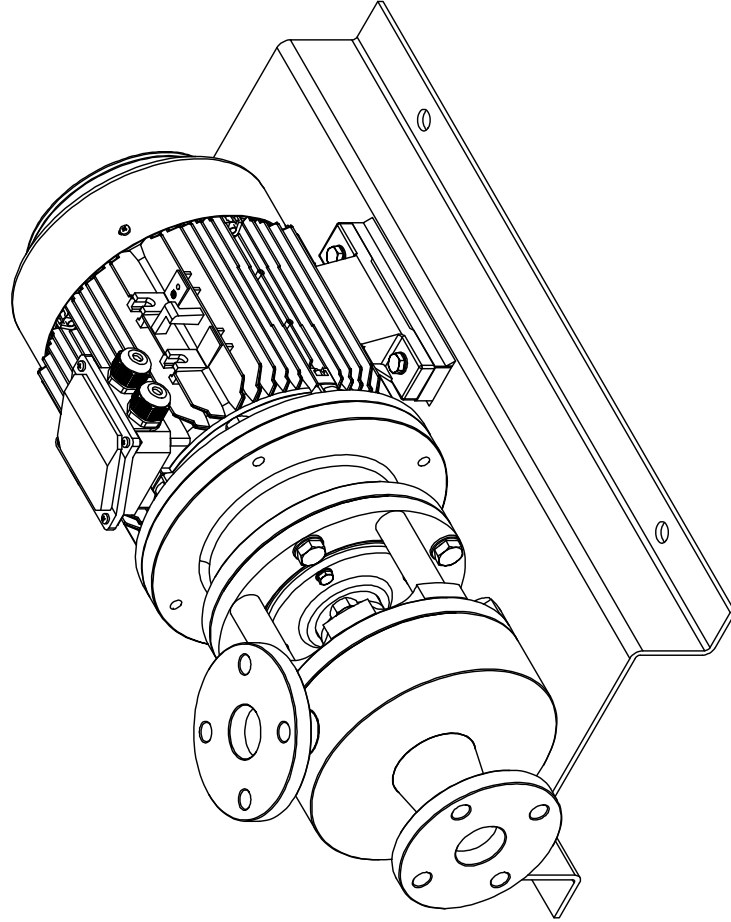
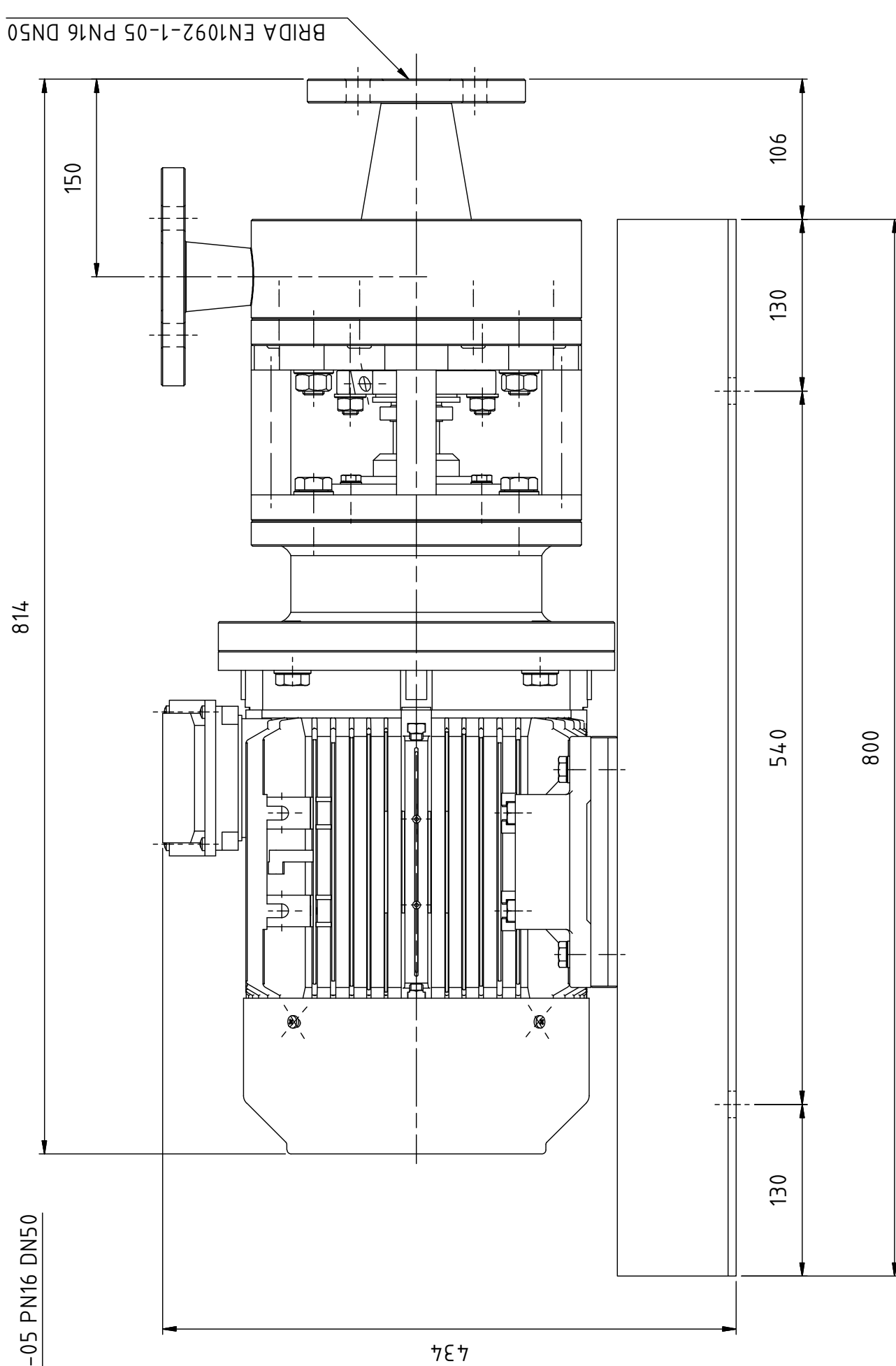
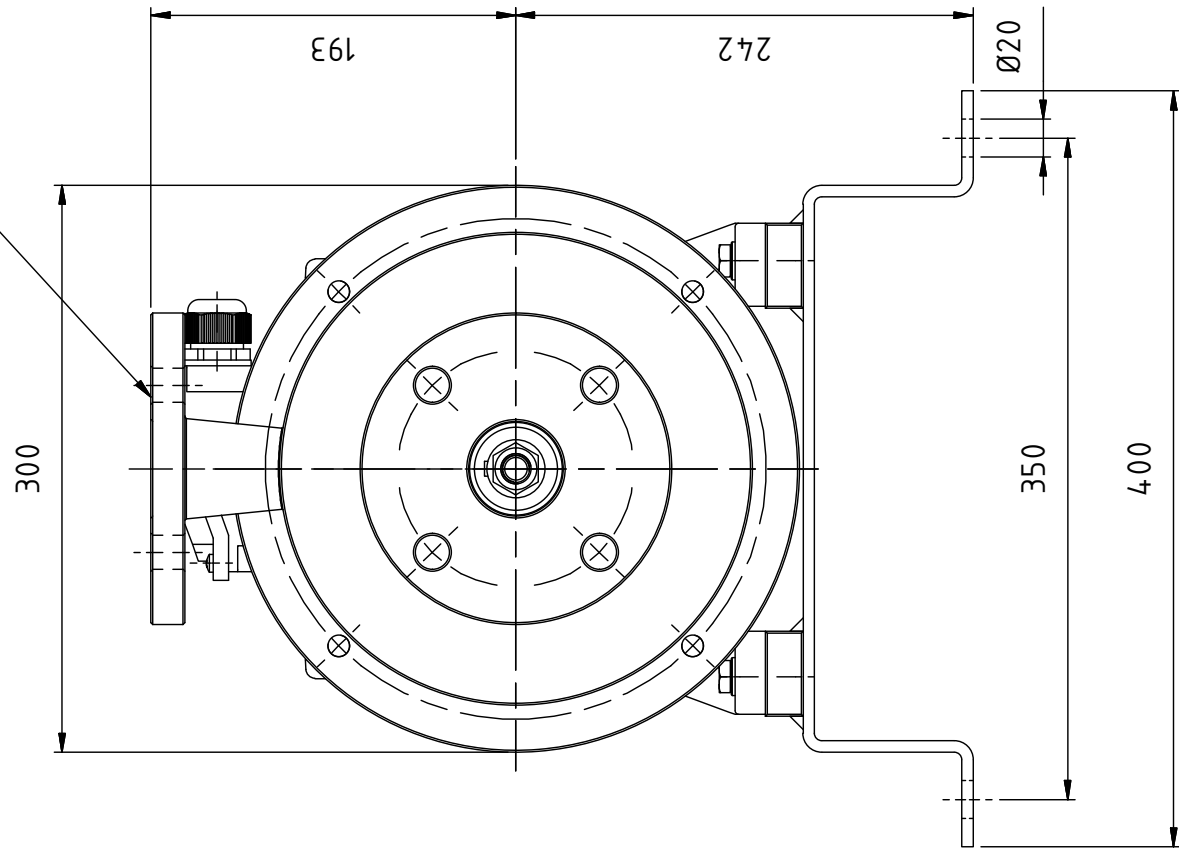

Escala 1 : 4	Descripción Emulsionador Ø145 monoblock	Nombre	Fecha
		Dibujado: Revisado:	16/02/2021 29/09/2023
Nombre de la entidad <b>COMQUIMA EUROPE</b>			
Código de plano <b>A3</b>	145-1	5,5/7,5	

BRIDA EN1092-1-05 PN16 DN50

300

REGATA PARA TÓRICA 105,00X5,00

250

193

434

210

8x M16X30

242

350

Ø20

400

708

43.5

130

540

130

800

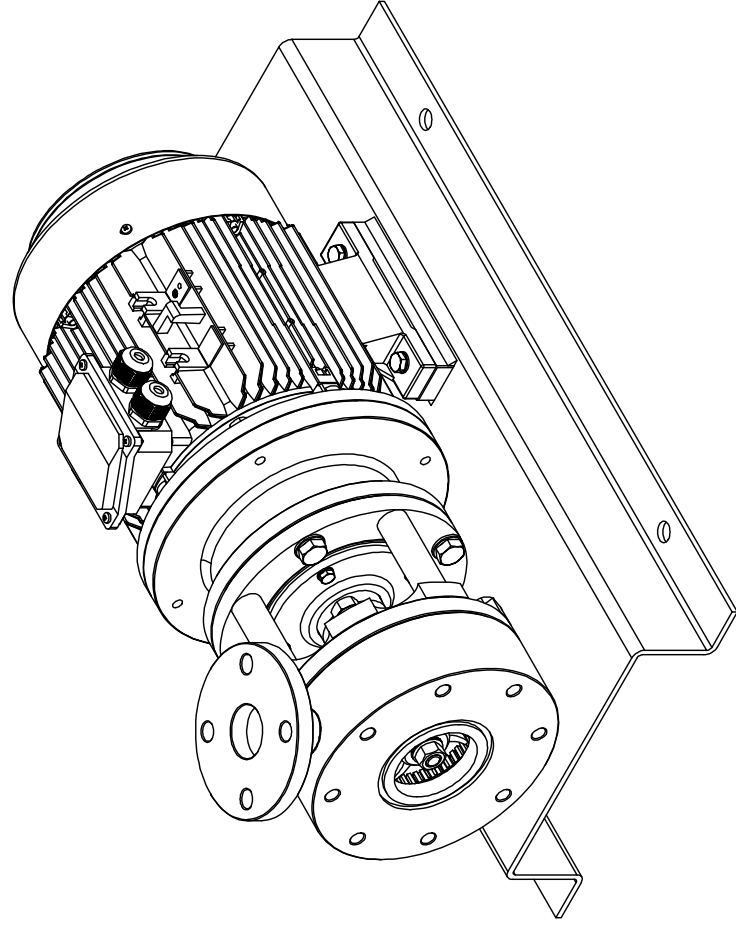

Escala 1 : 4	Descripción Emulsificador Ø145 monoblock	Nombre	Fecha
		Dibujado: Revisado:	02/10/2023
Nombre de la entidad <b>COMQUIMA EUROPE</b>			
Código de plano <b>A3</b>	145-2	5,5/7,5	

CLAMP DIN32676-A DN50 - 64 x 53

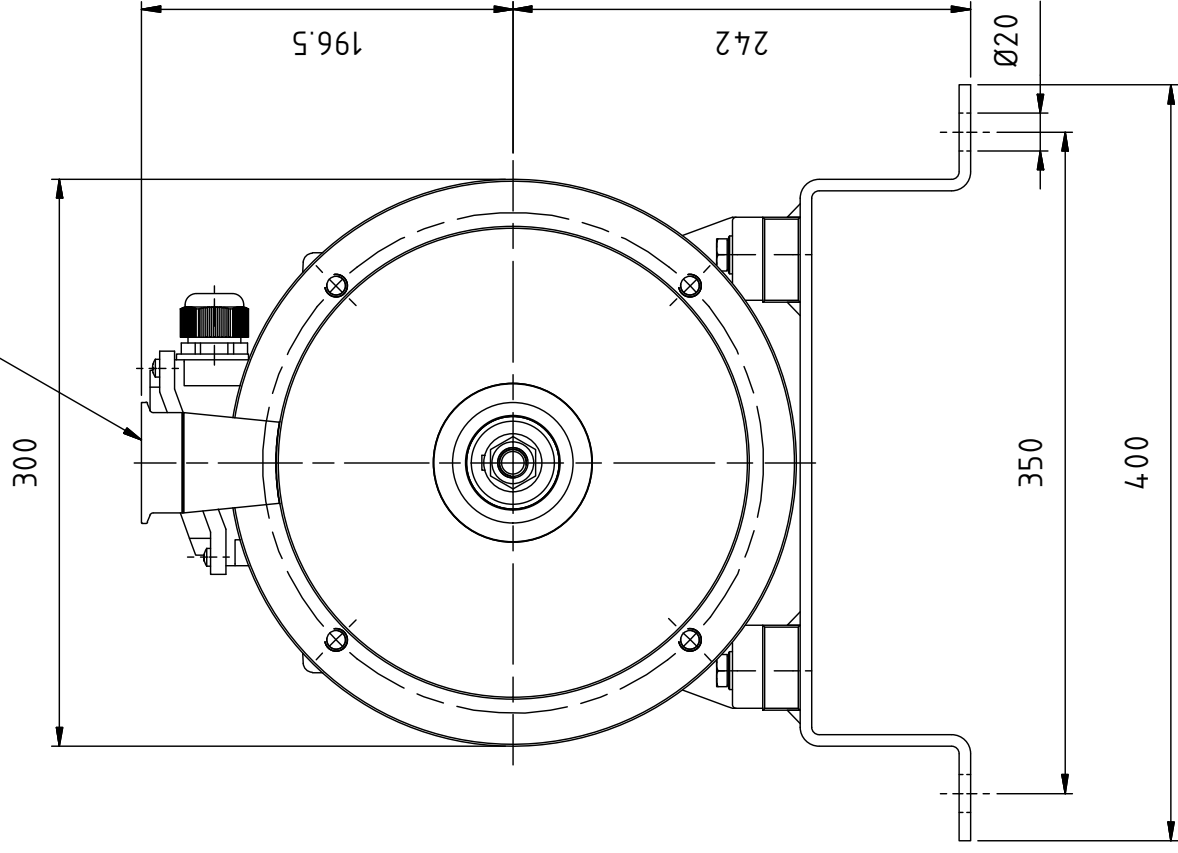

818

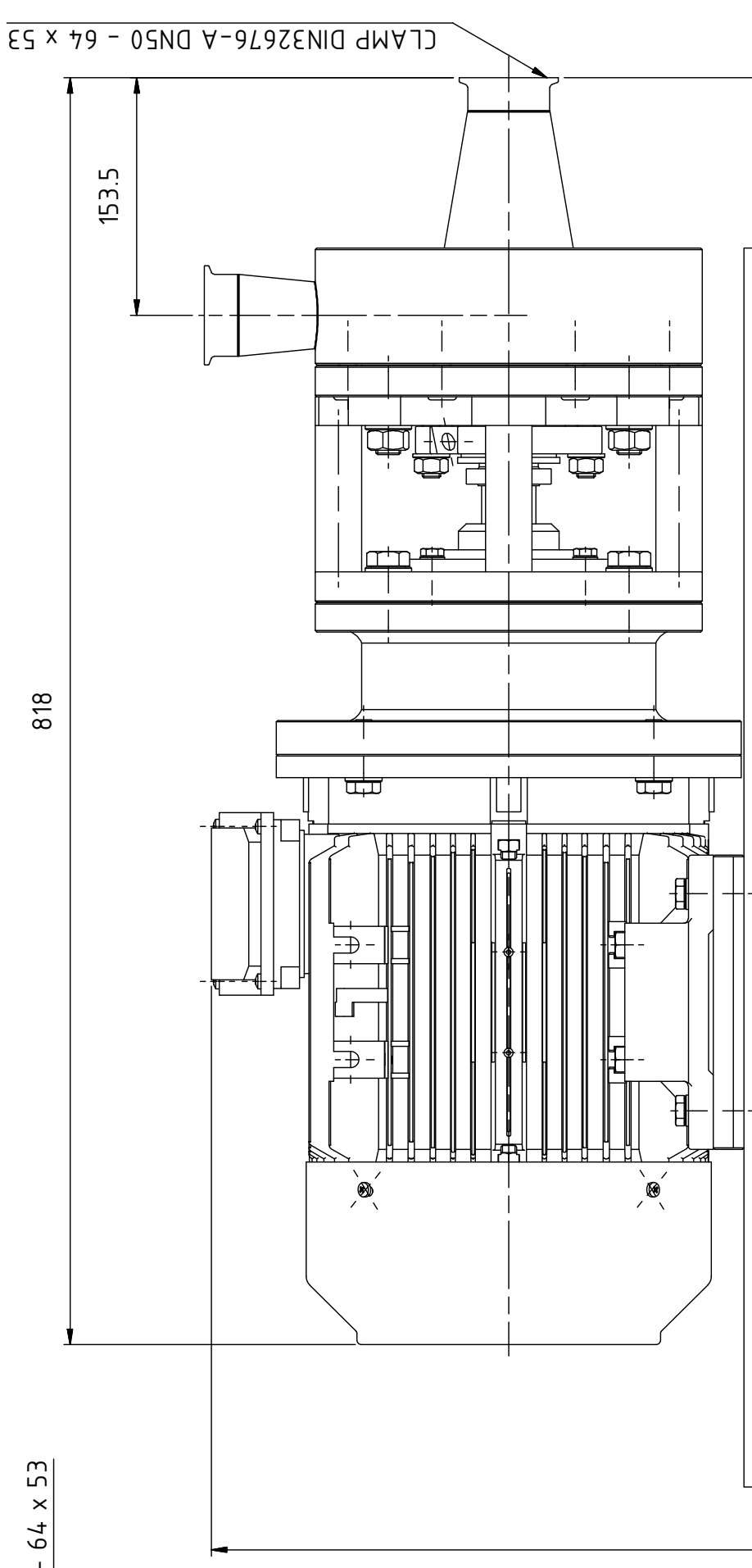

CLAMP DIN32676-A DN50 - 64 x 53

734

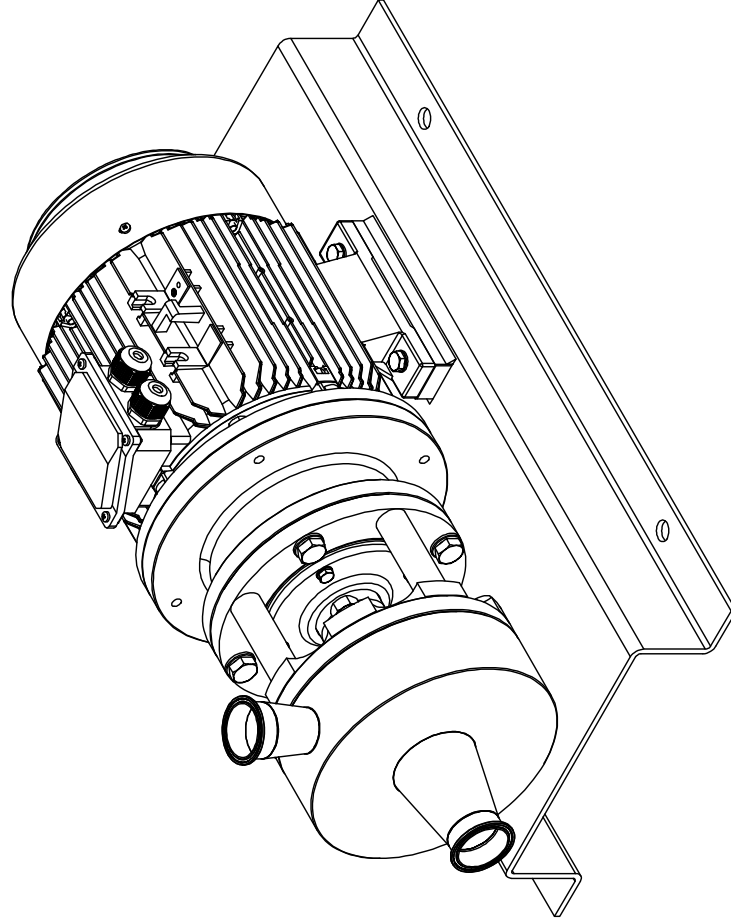
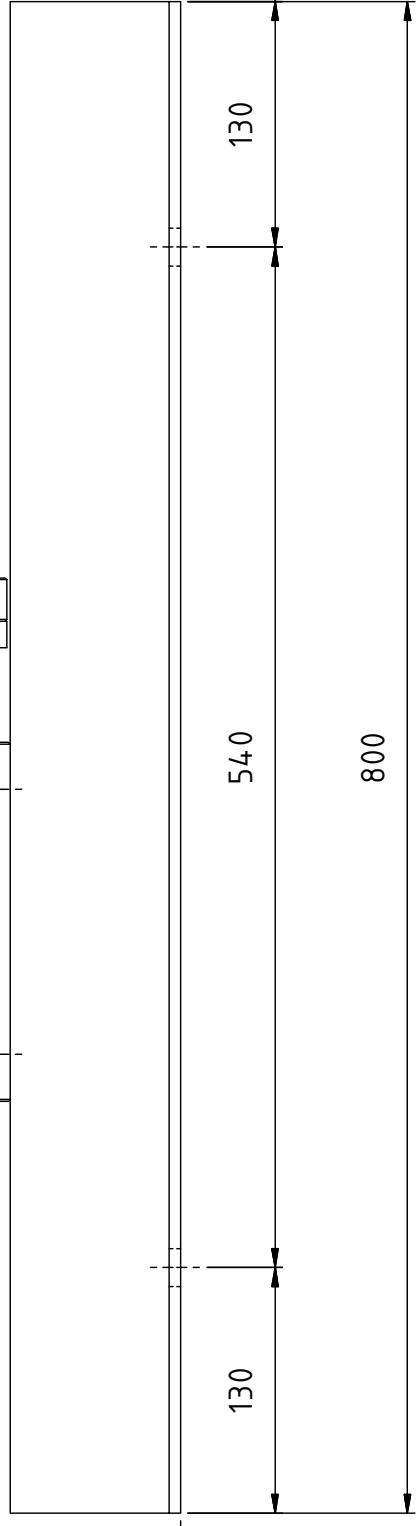

Esca 1 : 4	Descripción Emulsionador Ø145 monoblock	Nombre	Fecha 02/10/2023
	Nombre de la entidad <b>COMQUIMA EUROPE</b>	Dibujado:	Revisado:
A3	Código de plano 145-3	5,5/7,5	

CLAMP DIN32676-A DN50 - 64 x 53

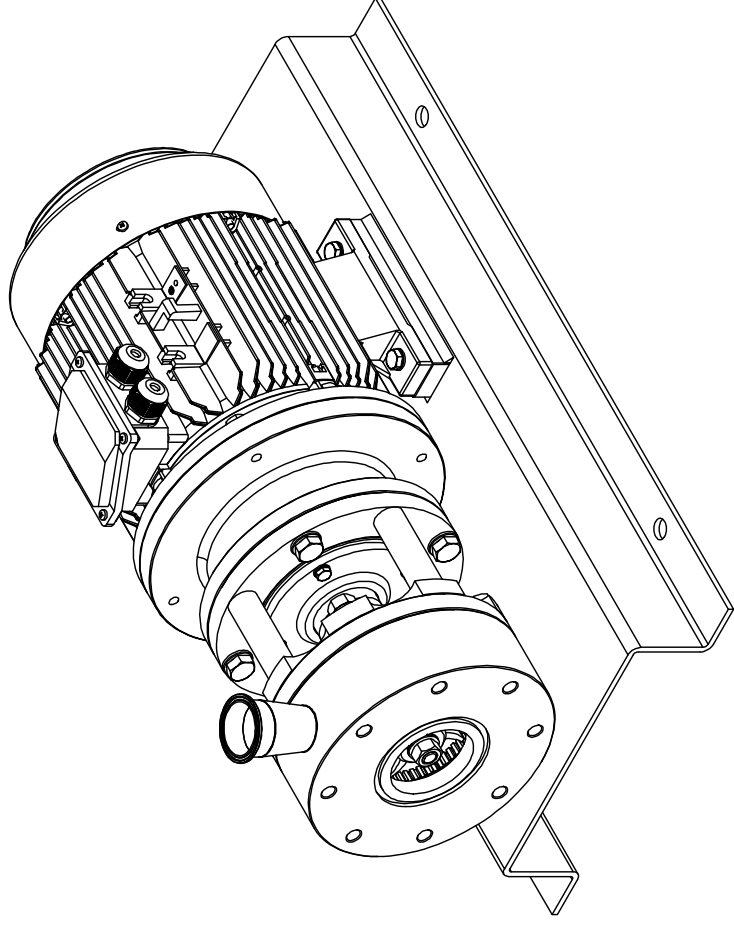
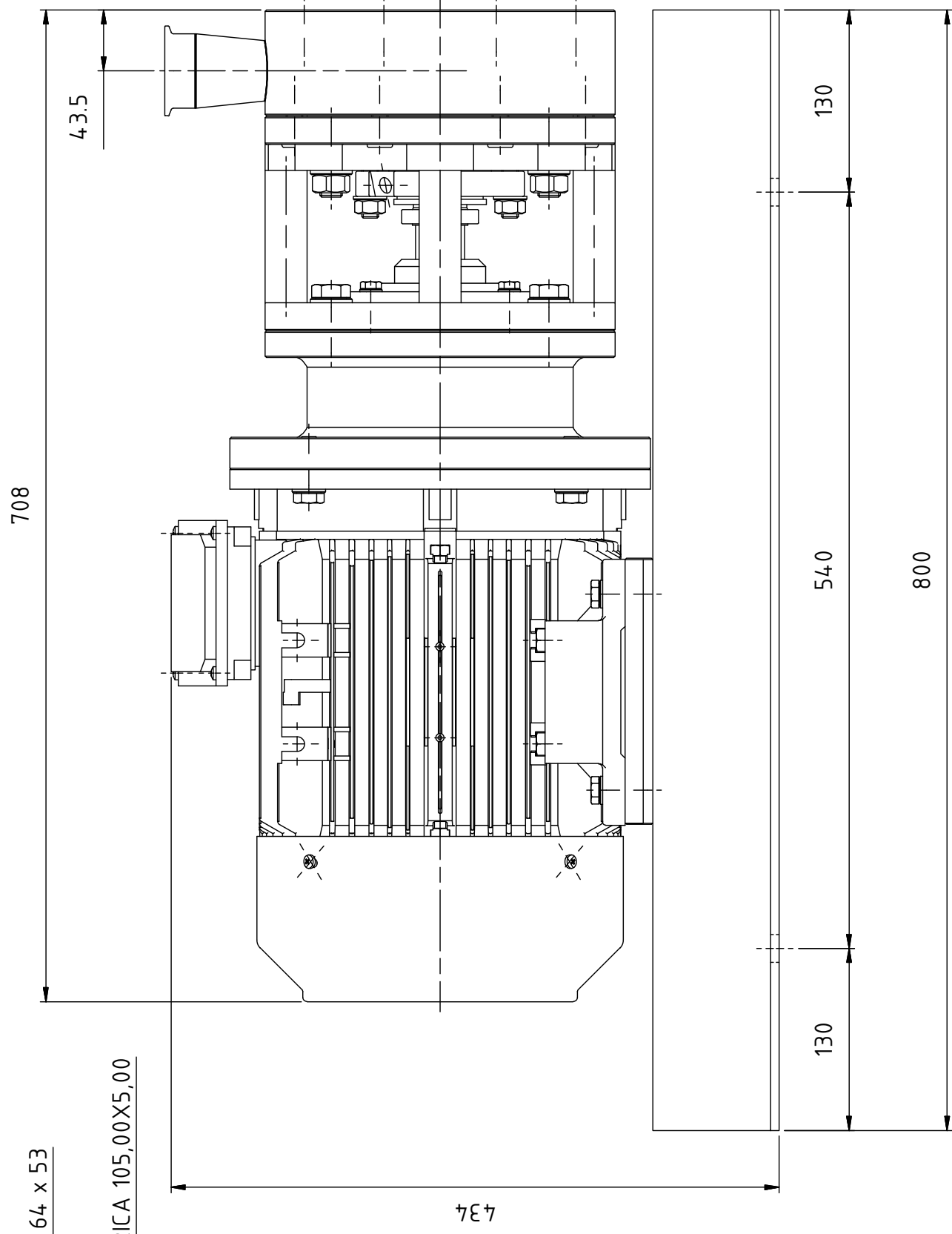
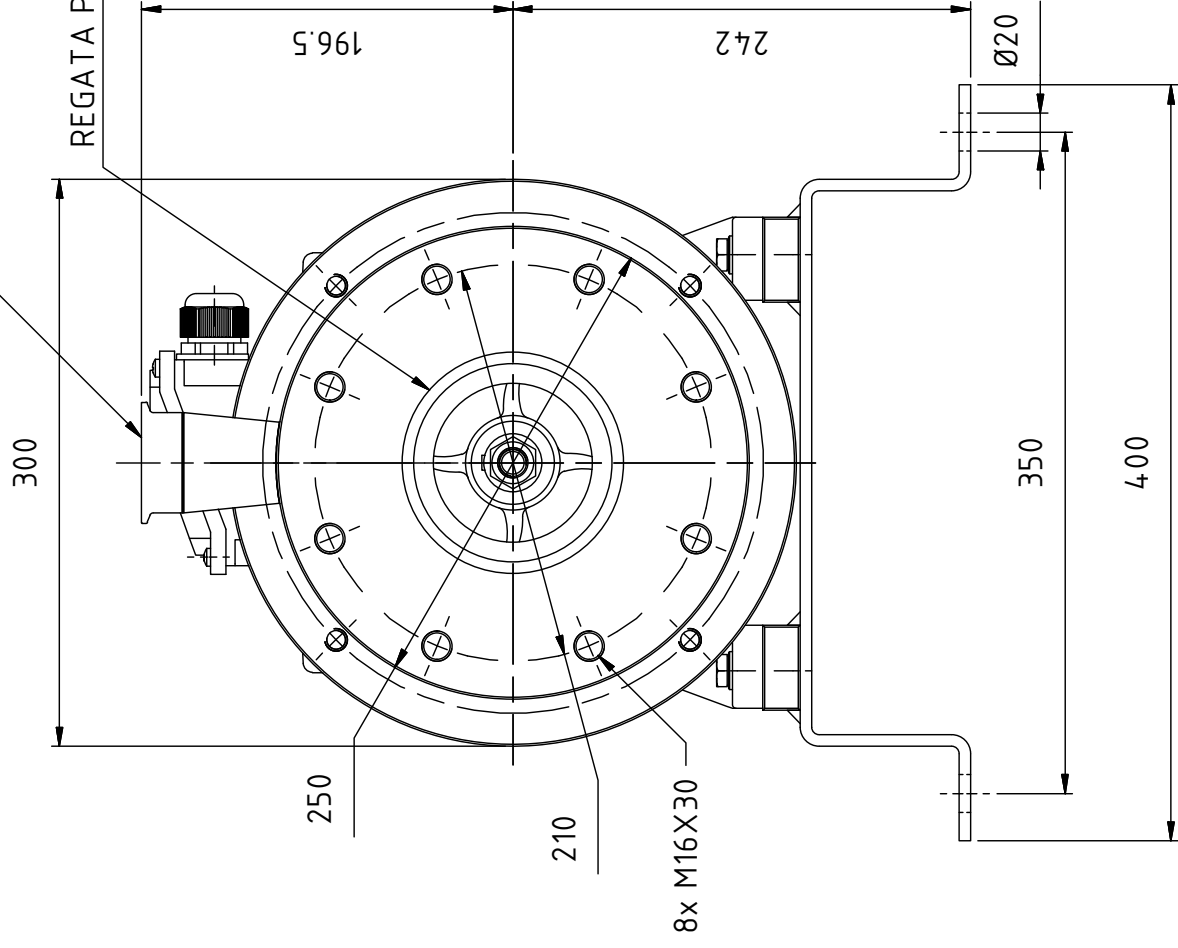

Escala 1 : 4	Descripción Emulsificador Ø145 monoblock	Nombre	Fecha
		Dibujado: Revisado:	02/10/2023
	Nombre de la entidad <b>COMQUIMA EUROPE</b>		
A3	Código de plano 145-4	5,5/7,5	

BRIDA EN1092-1-05 PN16 DN50

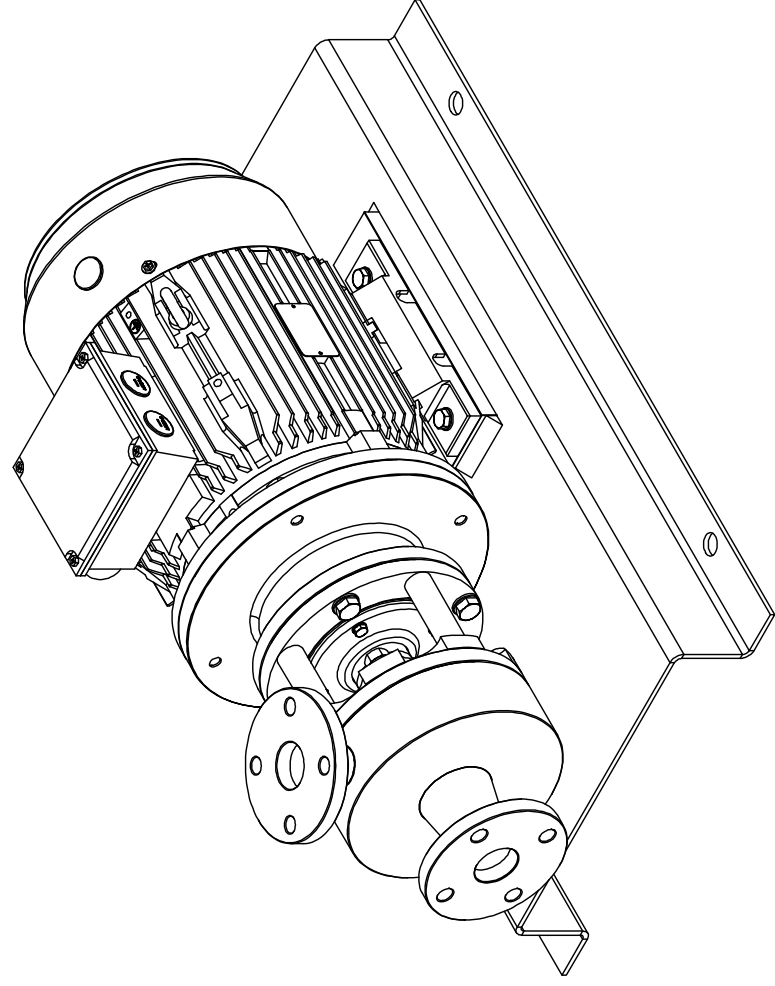
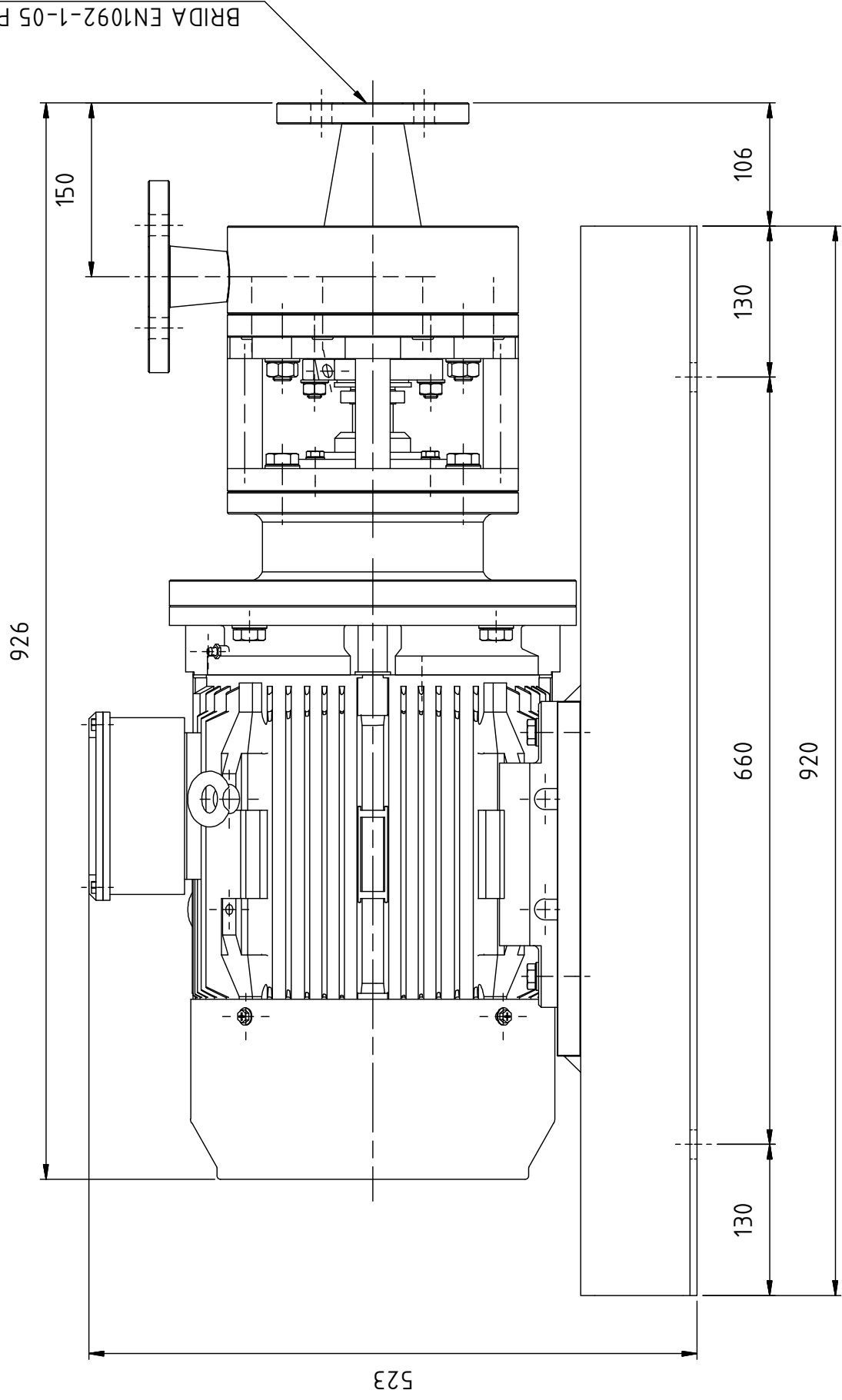
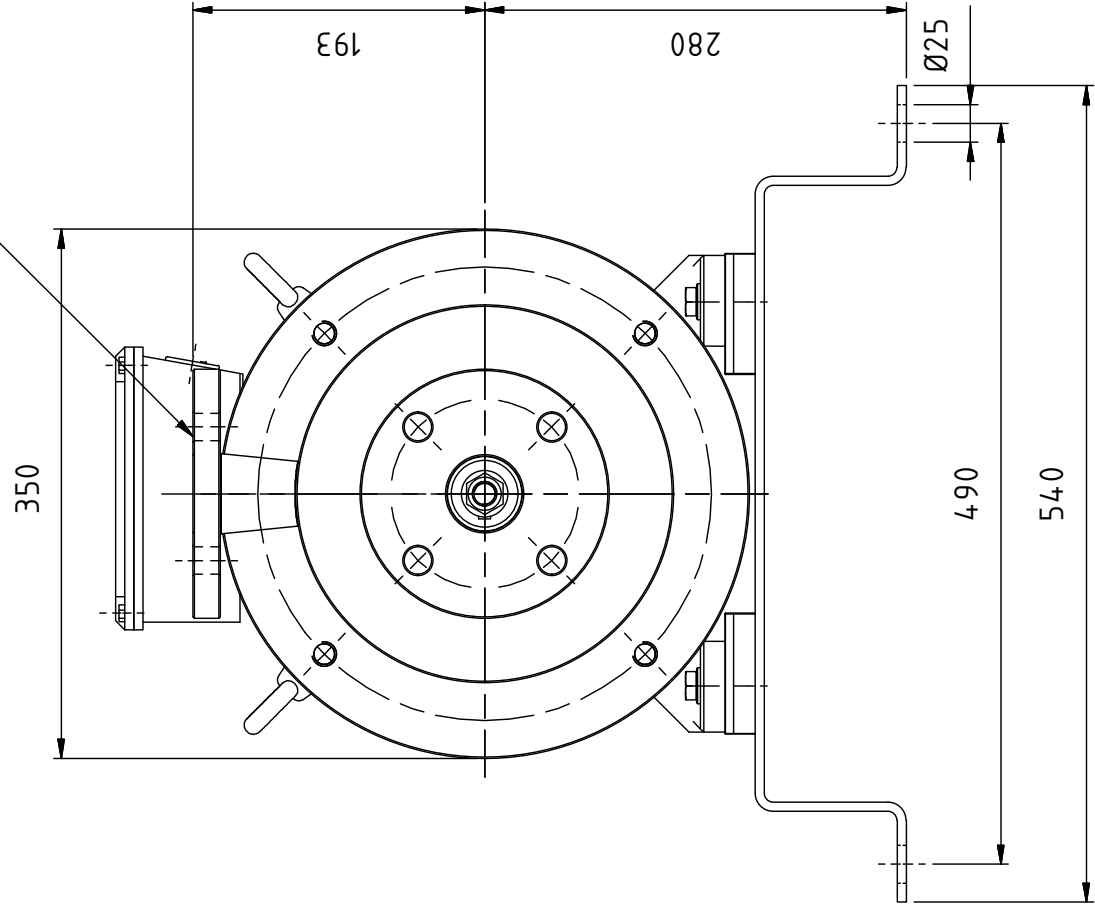

Esca	1:5	Descripción	Emulsionador Ø145 monoblock	Nombre		Fecha	11/03/2024	
				Dibujado:		Revisado:		
				Nombre de la entidad				
				<b>COMQUIMA EUROPE</b>				
				Código de plano				
				145-1				11 Kw

BRIDA EN1092-1-05 PN16 DN50

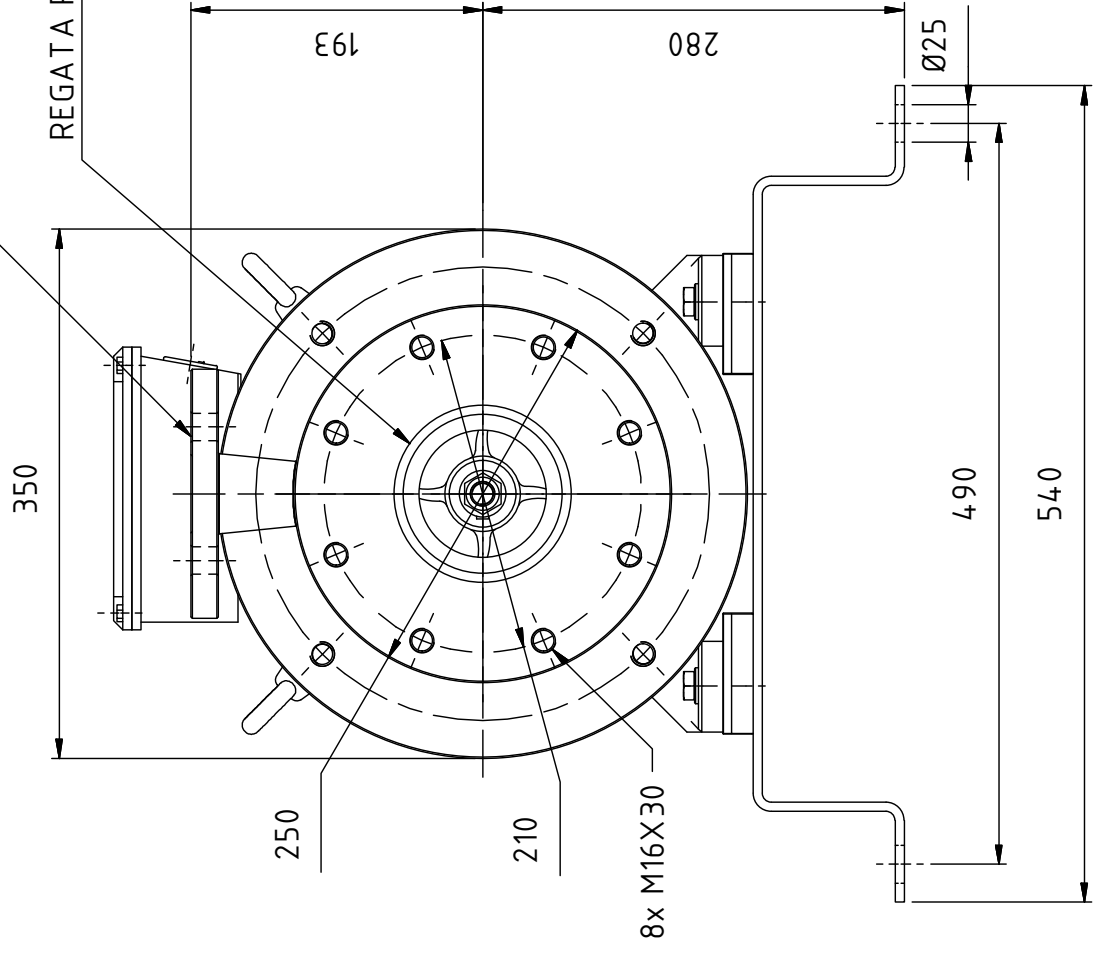

REGATA PARA TÓRICA 105,00X5,00

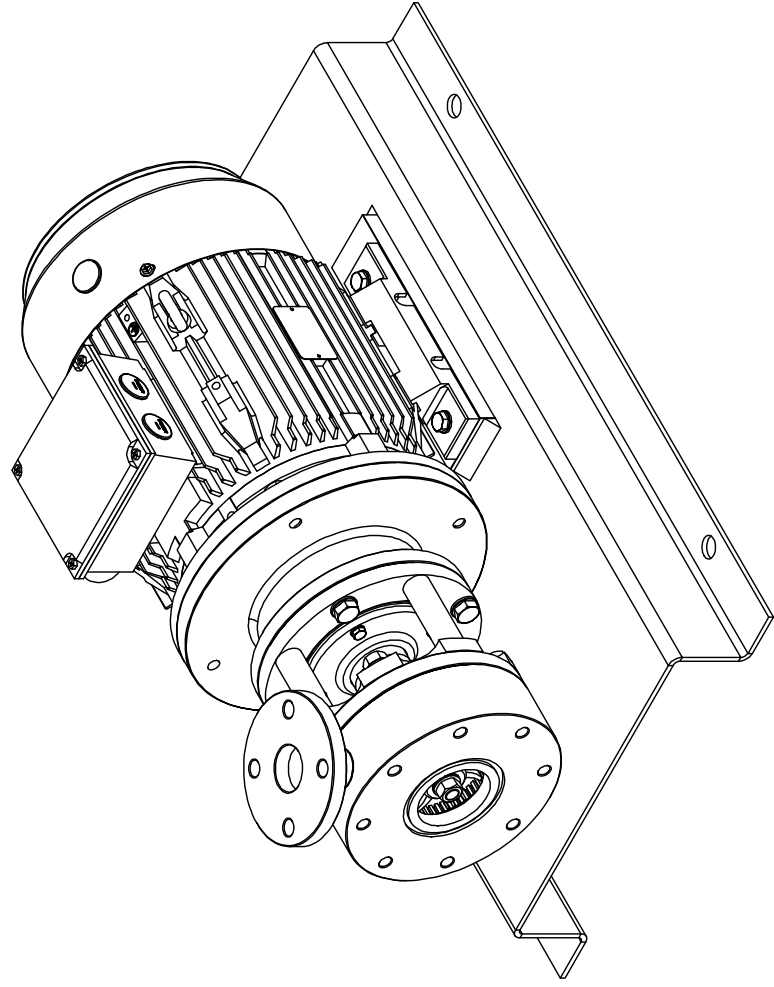
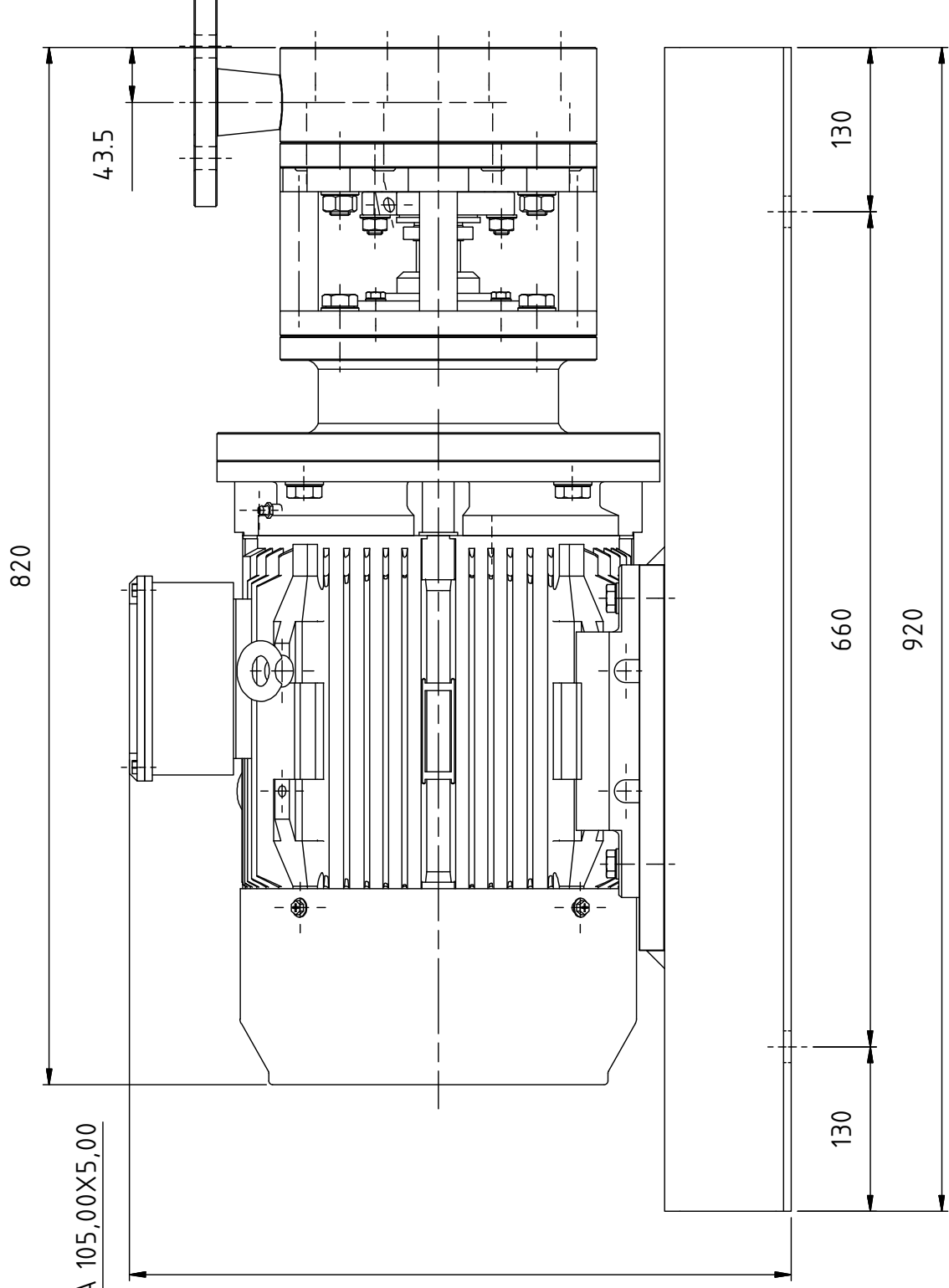

Esca	1:5	Descripción	Emulsionador Ø145 monoblock	Nombre		Fecha	11/03/2024	
				Dibujado:		Revisado:		
				Nombre de la entidad				
				<b>COMQUIMA EUROPE.</b>				
				Código de plano				
				145-2				11 Kw

CLAMP DIN32676-A DN50 - 64 x 53

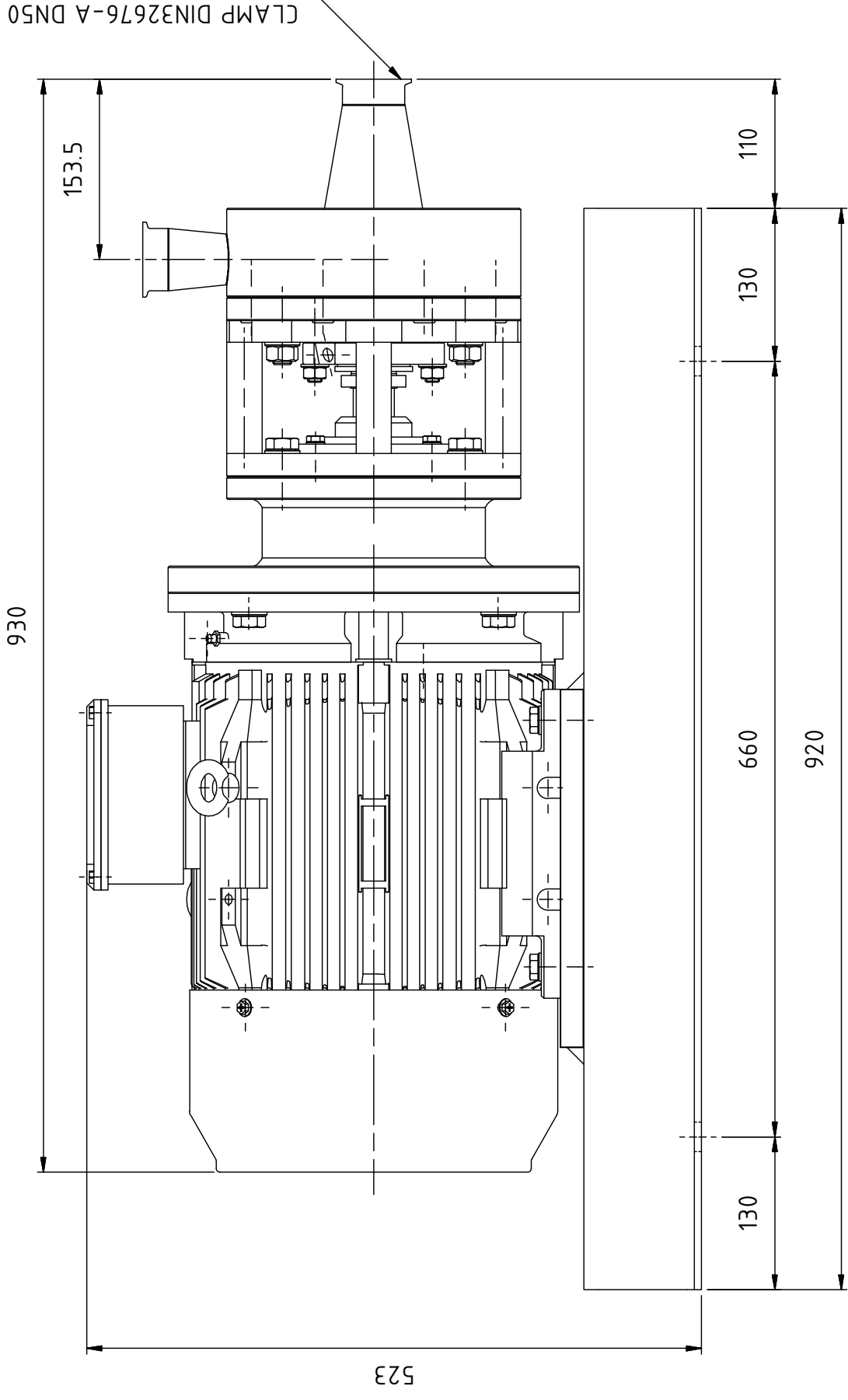
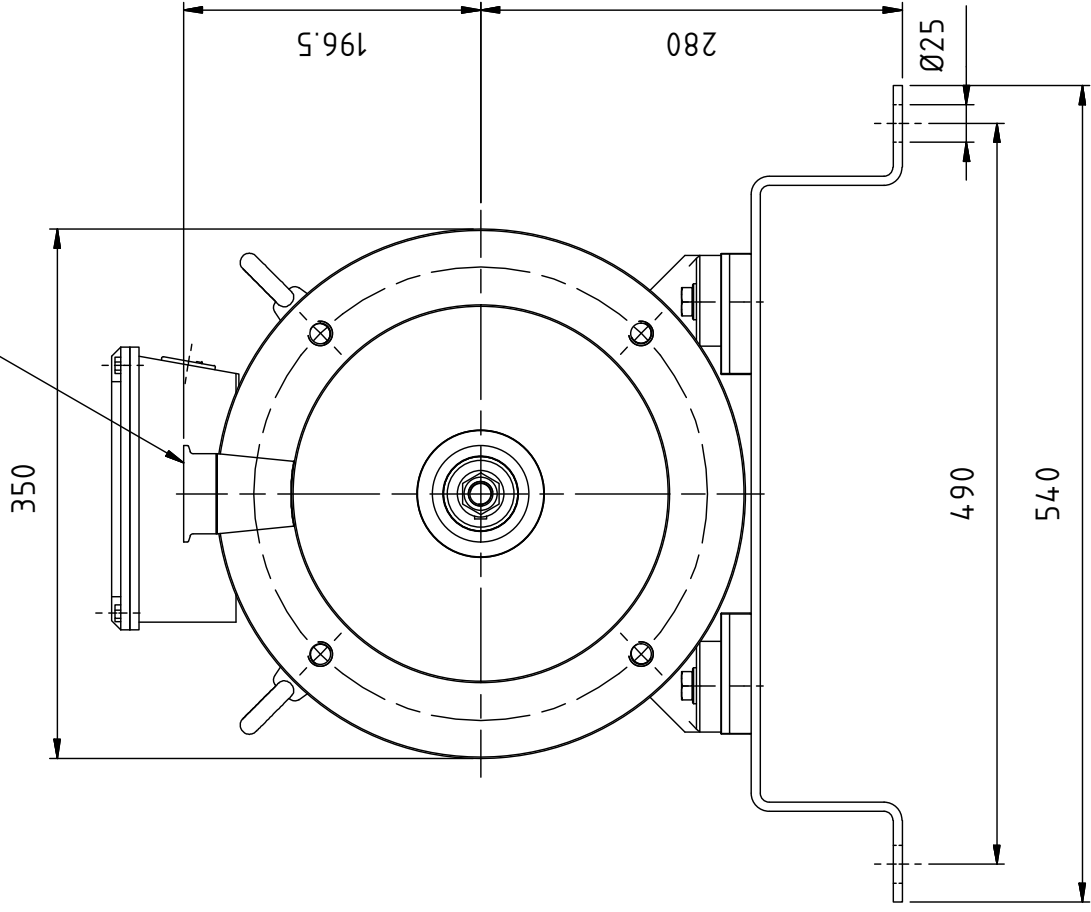

CLAMP DIN32676-A DN50 - 64 x 53

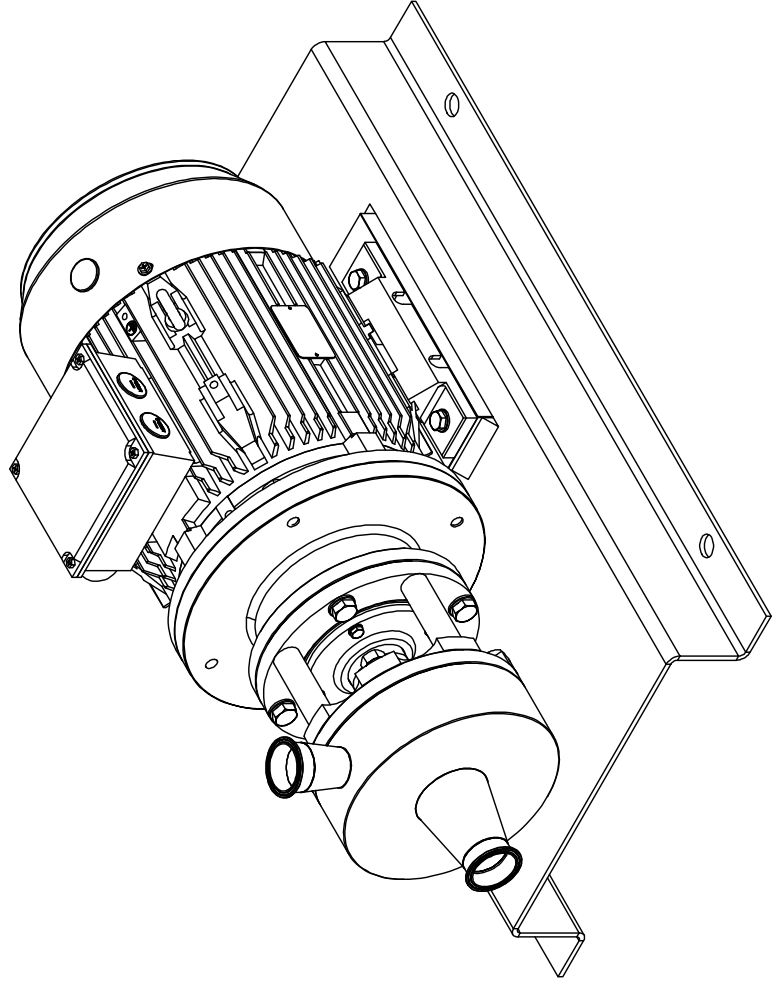

Esca 1:5	Descripción Emulsionador Ø145 monoblock	Nombre	Fecha 11/03/2024
	Nombre de la entidad <b>COMQUIMA EUROPE</b>	Dibujado:	Revisado:
A3	Código de plano 145-3 11Kw		



CLAMP DIN32676-A DN50 - 64 x 53

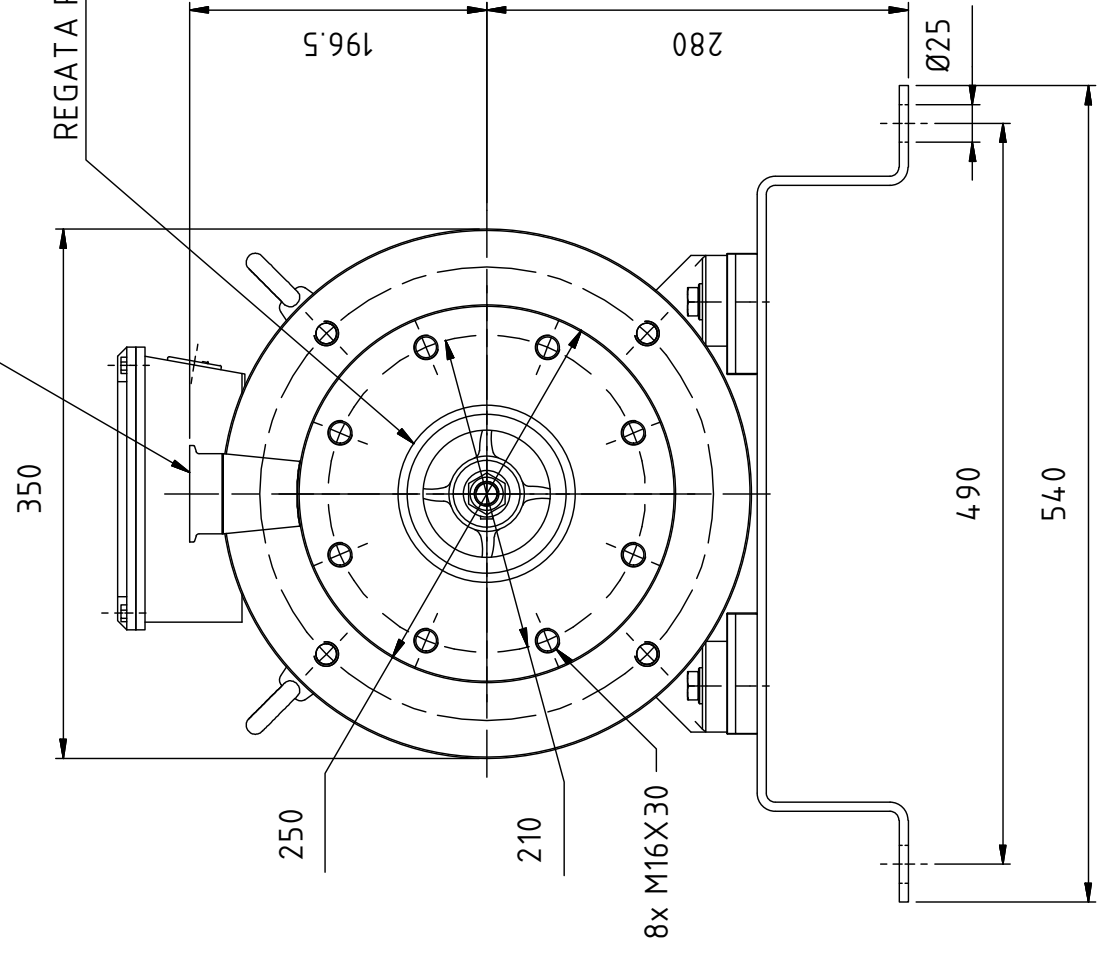

REGATA PARA TÓRICA 105,00X5,00

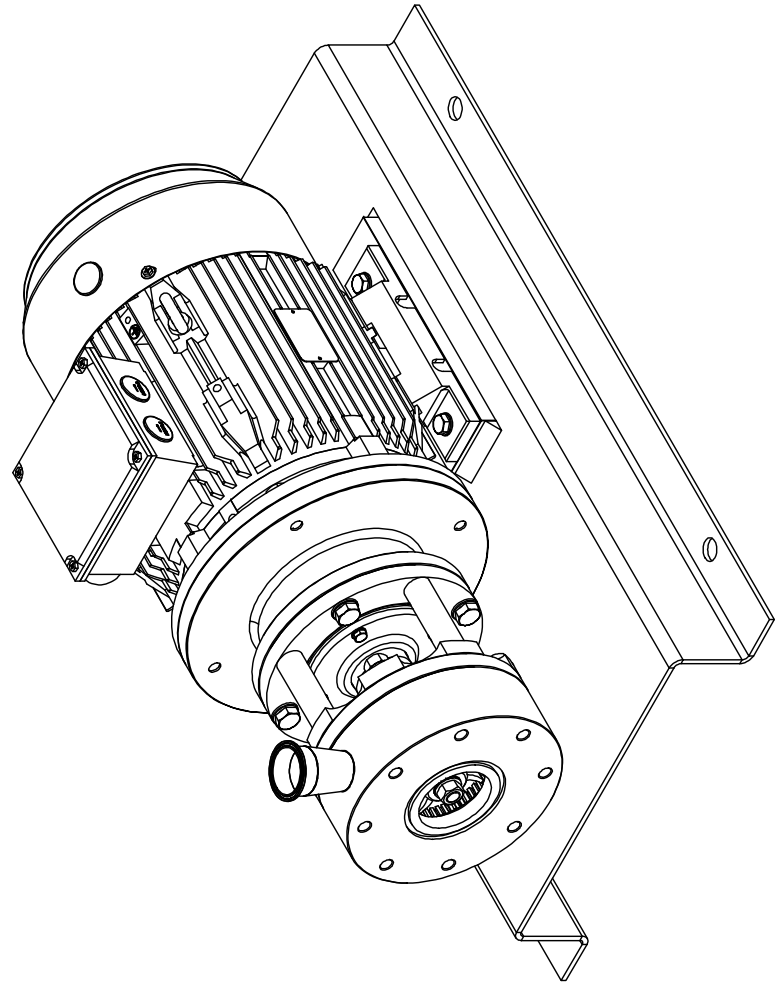
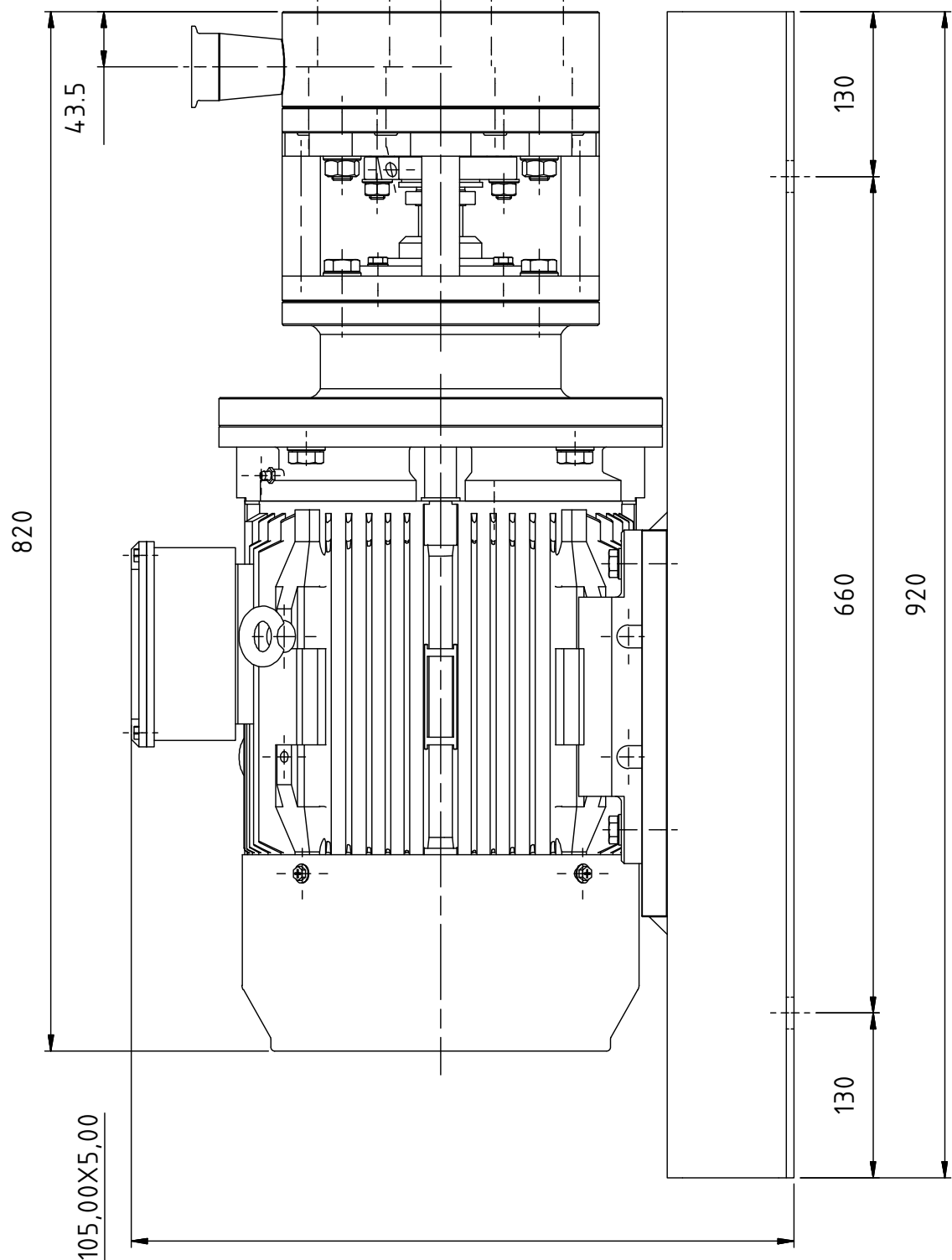

Escała	1 : 5	Descripción	Emulsionador Ø145 monoblock	Nombre		Fecha	11/03/2024	
				Dibujado:		Revisado:		
				Nombre de la entidad				
				<b>COMQUIMA EUROPE</b>				
				Código de plano				
				145-4				11 Kw